

STEP 2: Attach Arm to Mounting Post

Top Mount

Align groove in Arm Post with Screw on Mounting Post and slide Arm Post into Mounting Post (b). Secure with screw (a).

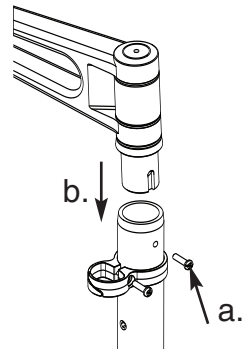

Bracket Mount

Place bracket on Mounting Post (c). Tighten knob (d) to secure at desired height.

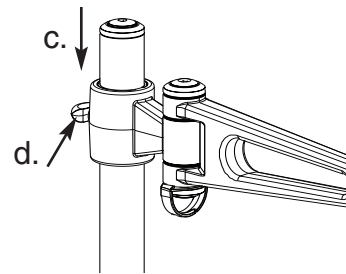

STEP 3: Attach VESA Bracket to Monitor

1. Select 75mm or 100mm VESA Bracket to match hole pattern on back of monitor.

2. Place VESA Bracket (b) in position on back of monitor with cut-out toward top of monitor (a) and attach using (4) screws provided. For this, you may also use screws that came with your monitor.

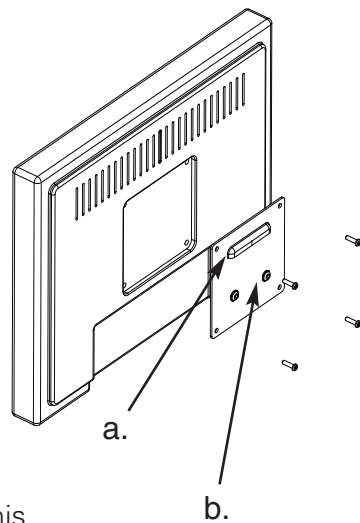

STEP 4: Attach Monitor to Monitor Arm

1. Place cut-out on VESA Bracket over Lip at end of Arm (a). If your arm is equipped with a Quick-Release Lever (b), simply push bottom of monitor into Arm until you hear a click. To remove, depress Quick Release Lever and remove monitor from Arm.

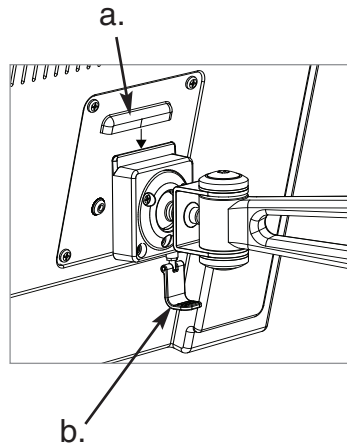

2. If your Arm is not equipped with a Quick Release Lever, secure monitor to Arm using (2) screws (c), as shown.

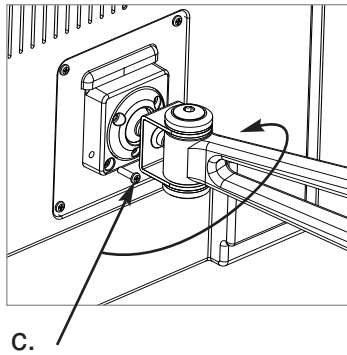

CABLE MANAGEMENT

The M7 includes cable management clips for the arm(s) and for the pole to keep monitor cables neat and protected. If desired, route the monitor and power cables through clips as shown. The clip for the pole must be opened and slipped over the pole and then secured with the supplied screw to the desired height as indicated.

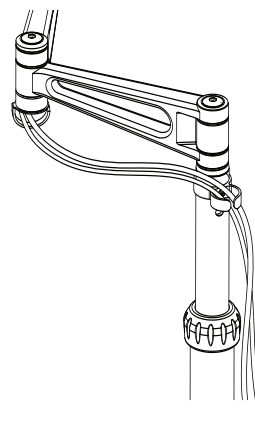

FRICITION ADJUSTMENTS

1. If your monitor is particularly heavy, or after prolonged use, the Ball Joint may require increased friction. This can be achieved by tightening the (3) Ball Joint Friction Screws (a).

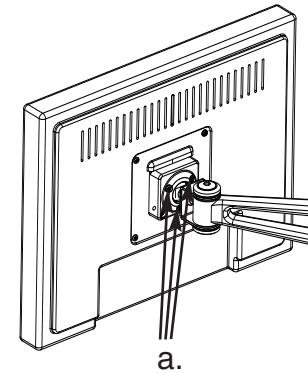

2. If you would like to increase friction on the height adjustable post or secure the post at one particular height, turn the Friction Dial (b) clockwise until the desired level of friction is achieved. To decrease friction for easier height adjustability, turn the Friction Dial counter-clockwise.

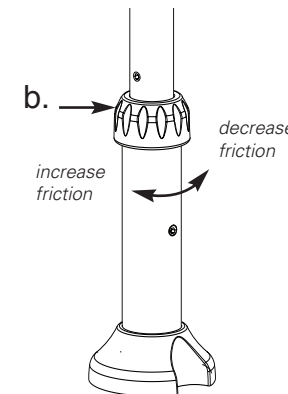

M7 Desk Mount Installation Instructions



STEP 1: Identify your base mount and follow corresponding instructions.

Clamp Mount

1. Remove Bottom Assembly from Base by loosening screws (a) with hex key.

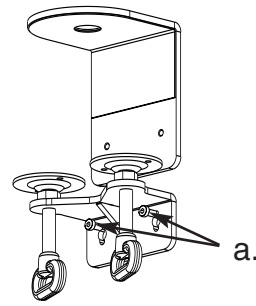

2. Place Vertical Assembly on Base (b). Make sure the External Tube is loosely secured by lining up cut-out with guide inside Base (c).

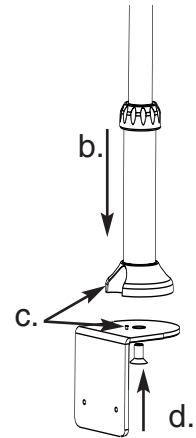

3. Use M12 screw and hex key to secure the Vertical Assembly to the Base (d). Make sure the screw face is flush with the underside of the Base.

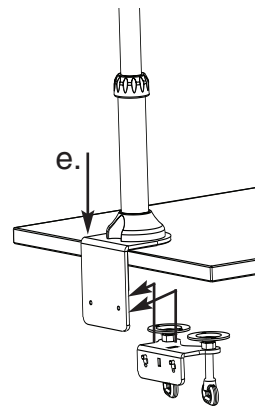

4. Position Base at desk edge (e).

5. From under desk, reattach Bottom Assembly (f). Tighten Screws (a) and Clamp Disk Screws (g) to secure.

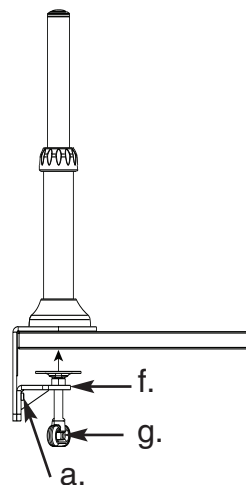

Proceed to "Step 2: Attach Arm to Mounting Post"

Low Profile Mount

1. Follow steps 2-3 for Clamp Mount. *Note: Low Profile Mount cannot be disassembled.*

2. Slide base onto mounting edge (a). Tighten Clamping Screws (b) with hex key.

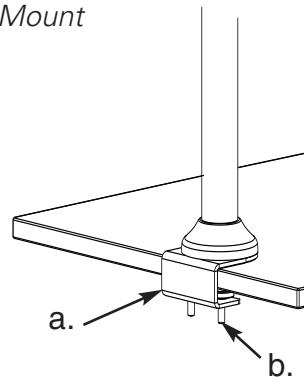

Proceed to "Step 2: Attach Arm to Mounting Post"

Direct Mount

1. Position unit in desired location on work surface.

2. Secure using four screws and washers as shown.

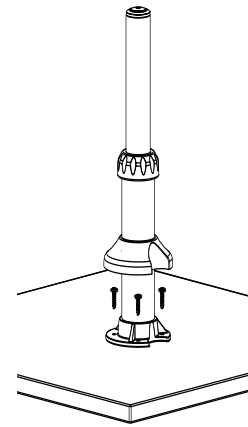

Proceed to "Step 2: Attach Arm to Mounting Post"

Grommet Mount

1. Separate the grommet mount assembly (bracket, mounting screws and backing plate) from the M7 pole assembly (a) by loosening the (2) pinch screws (b) and sliding it off the end of the pole. Leave the plastic cover on the pole.

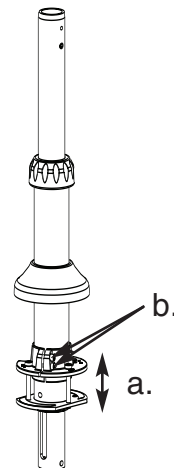

Grommet Mount (continued)

2. Remove lower plate (c) from grommet assembly by removing the (3) mounting screws (d). Remove backing from adhesive tape and place lower plate on underside of work surface, concentric with grommet hole.

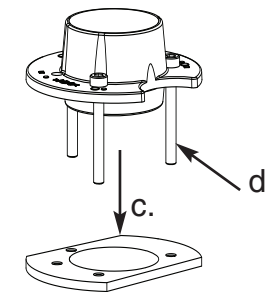

3. Position upper mount into grommet hole.

4. Determine which (3) of the (4) available mounting holes are needed for the specific grommet hole. Determine by using the hole style indicator (e) which is next to each hole.

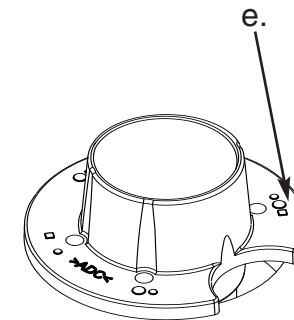

- 3-small circles for small circular grommet holes. From 2.5" - 2.75"
- 3-large circles for large circular grommet holes. From 2.75" - 3.125"
- 3-squares for rectangular 2 x 4 style grommet holes

5. Align (3) mounting screws with holes in lower plate. Snug (3) screws to table (f) but do not tighten.

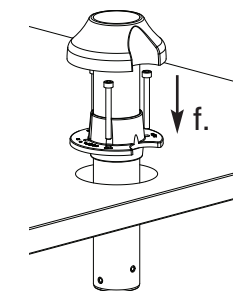

Grommet Mount (continued)

6. Insert vertical assembly (pole) into mount and tighten pinch screws (b) with pole at desired height.

7. Fully tighten (3) screws (d) that hold base to desk.

8. Lower plastic cover (g) down to cover upper mount.

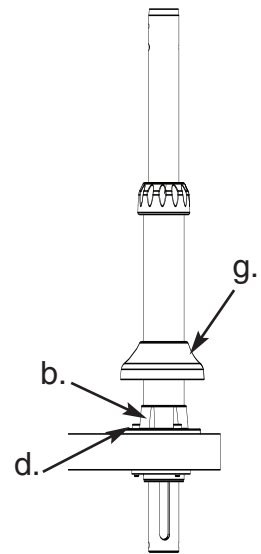

Bolt Mount

1. Drill 1/2" hole through desk in desired location.

2. Apply protective foam sheet to bottom of base if desired.

3. Pass large bolt through hole in curved plate (a). Make sure to note the direction of the curve. Pass bolt through hole in desk and screw into vertical assembly (pole).

4. Verify that the small hole (c) at the top of the pole is facing away from the user and then tighten large bolt with the provided hex key.

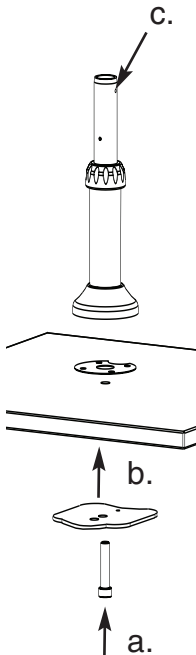

Proceed to "Step 2: Attach Arm to Mounting Post"